

# STILNOVO

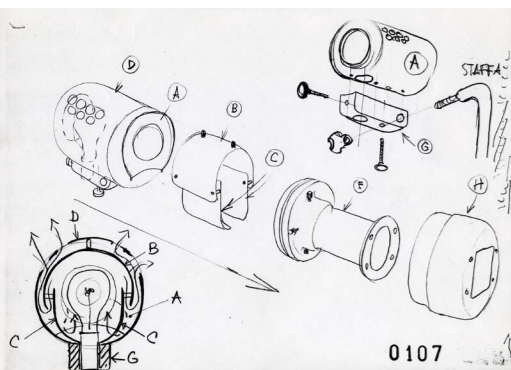
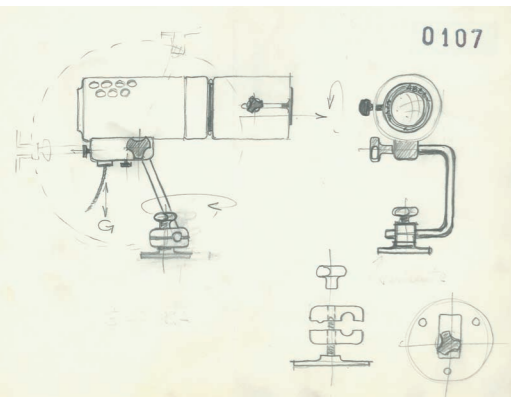

La nuova avventura Stilnovo riparte grazie ad un team di imprenditori italiani fortemente motivati a rilanciare questo storico e autentico marchio Made in Italy. Fondata a Milano da Bruno Gatta, nel 1946, per decenni Stilnovo è l'entità più significativa nel panorama del design dell'apparecchio luce. Laboratorio, fucina di idee, sin dagli anni della ricostruzione e del primo boom economico, Stilnovo suscita l'interesse della storica testata "Domus", assurgendo a punto di riferimento imprescindibile per i nomi prestigiosi del design italiano, da Achille e Pier Giacomo Castiglioni, a Joe Colombo, Danilo e Corrado Aroldi, Roberto Beretta, Antonio Macchi Cassia, lo studio De Pas D'Urbino Lomazzi, Ettore Sottsass, Cini Boeri, Gae Aulenti, che disegnano per la piccola entità milanese pezzi memorabili. La riedizione di pezzi iconici importanti e il coinvolgimento di nuove leve del design italiano e internazionale nello sviluppo di oggetti inediti, sono solo alcuni dei progetti nell'agenda Stilnovo, capaci di portare nuovi stimoli e una vivace collaborazione tra artigiani e progettisti, garantendo ancora una volta un prodotto 100% Made in Italy.

The new Stilnovo adventure gets its start from a team of Italian businessmen who are strongly motivated in relaunching this historical and authentic Made in Italy brand name. Founded in Milan by Bruno Gatta, in 1946, Stilnovo was for years the most important reality in the world of lighting equipment design. It was a laboratory and a hotbed of ideas during the post-war reconstruction and the following economic boom. Stilnovo triggered interest from the historical publication "Domus", to become an essential point of reference for prestigious names in Italian design, such as Achille and Pier Giacomo Castiglioni, Joe Colombo, Danilo and Corrado Aroldi, Roberto Beretta, Antonio Macchi Cassia, De Pas D'Urbino Lomazzi Studio, Ettore Sottsass, Cini Boeri and Gae Aulenti who designed memorable pieces for this small Milanese company. The recreation of important iconic pieces and the use of new stimuli of Italian and international design in order to create completely new pieces represent just some of the plans for Stilnovo, which in themselves will bring new stimuli and lively collaboration among craftsmen and planners in order to guarantee as always 100% Made in Italy products.

**LE VIE  
DEL  
COMPASSO  
D'ORO**

Milan  
and around  
02.04  
12.09.2016

**ADI** ADI ASSOCIAZIONE  
PER IL DISEGNO  
INDUSTRIALE  
DELEGAZIONE  
LOMBARDIA

 Location (click for map)

**10 CORSO COMO**

Corso Como 10,  
Milano

 Opening

02.04-12.09.2016  
Mon-Sun 10.30-19.30  
Wed-Thu 10.30-21.00

Design week 12-18.04.2016  
10.30-21.00

 Info

+39 02 29002674  
[www.10corsocomo.com](http://www.10corsocomo.com)  
[shop@10corsocomo.com](mailto:shop@10corsocomo.com)

**Bazooka**, Joe Colombo,  
Honorable Mention at  
the Compasso d'Oro, 1970

photo: Ignazia Favata-Studio Joe Colombo

